

Red, Green, and Blue LEDs for White Light Illumination

Subramanian Muthu, *Associate Member, IEEE*, Frank J. P. Schuurmans, and Michael. D. Pashley

Abstract—The rapid improvement of the white light efficacy achievable with light-emitting diodes (LEDs) opens up new opportunities in the general illumination market. An LED light source made of red, green, and blue LEDs (RGB-LEDs) can provide the unique feature of color variability, allowing the user to select the desired color point of the lamp. The white light color accuracy required in the general illumination market is a challenge for LEDs. The variation in lumen output and wavelength for nominally identical LEDs and the change in these parameters with temperature and time result in an unacceptably high variability in the color point of white light from RGB-LEDs.

In this paper, we show that these problems can be overcome with suitable feedback control schemes that can be implemented in a practical LED lamp. We present results of experiment and theoretical modeling that shows the performance that can be achieved with a number of different control schemes.

Index Terms—Color accuracy, feedback control, light-emitting diodes, white light illumination.

I. INTRODUCTION

THE RAPID development of light-emitting diodes (LEDs) over the last few years has opened up new opportunities in the general illumination market [1]. The efficacy of white light from LEDs is now over 20 lm/W, which already exceeds that of incandescent lamps [2]. By 2005, it is forecast that LED efficacy will reach 50 lm/W [3], which approaches that of compact fluorescent lamps. In addition, higher power packages are becoming available that enable compact lighting systems with LEDs. However, additional challenges remain. The general illumination market has strict requirements on the quality of white light—lamps of the same type must all appear to have the same color point. In this paper, we discuss these requirements, the issues with LEDs that make these requirements a challenge, and how to meet these requirements.

There are several approaches using LEDs to achieve white light [4]. One approach is to use a blue or UV LED to excite one or more phosphors to give white light. In this paper, we focus on the use of red, green, and blue LEDs (RGB-LEDs) to produce white light. The advantages of RGB-LEDs are that they provide a light source that can have a variable color point, and theoretically can provide the highest efficiency LED-based white light. The ability to change the color point of the lamp provides a new feature to general illumination that has the potential to generate new applications and hence new market opportunities.

Manuscript received December 11, 2001; revised January 23, 2002.
S. Muthu and M. D. Pashley are with Philips Research, Briarcliff Manor, NY 10510 USA (Subu.Muthu@philips.com; Michael.Pashley@philips.com).
F. Schuurmans is with Philips Research, Eindhoven, The Netherlands (Frank.Schuurmans@philips.com).

Publisher Item Identifier S 1077-260X(02)03763-2.

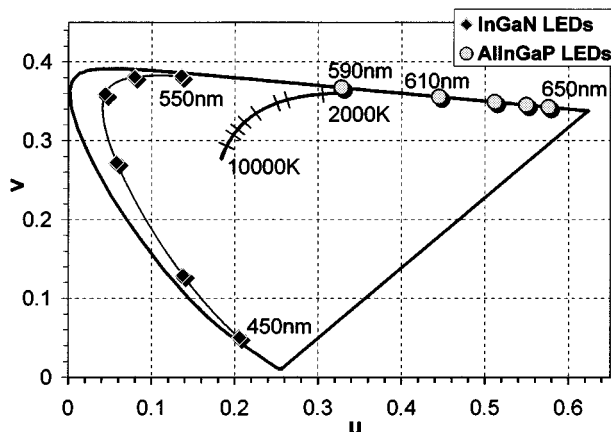

Fig. 1. The 1964 CIE (u, v) coordinate system showing the coordinates of InGaN and AlInGaP LEDs. Also shown is the blackbody line over a range of color temperatures from 2000 K to 10 000 K.

A key challenge for RGB-LEDs is to maintain the desired white point within acceptable tolerances. This arises from the significant spread in lumen output and wavelength of manufactured LEDs, and the changes in LED characteristics that occur with temperature and time. Maintaining the desired white point can only be achieved with feedback schemes to control the relative contributions of red, green, and blue to the white light.

II. WHITE LIGHT REQUIREMENTS

It is well known that red, green, and blue LEDs can be combined to produce white light. This can be represented on a chromaticity diagram. The most common chromaticity diagram is the CIE 1931 coordinate system (xy) [5]. However, the just noticeable color difference is not a constant length over xy space. By applying a linear transformation a new coordinate space can be generated where the just noticeable color difference is approximately uniform. A number of such transformations exist. For the purposes of this paper we use the CIE 1960 UCS system (uv), as shown in Fig. 1. By combining three different color LEDs, it is possible to produce any color point ((u, v) coordinate) that lies within the triangle formed by the (u, v) coordinates of the three LEDs. In almost all white light illumination applications, the resultant color point must lie on, or very close to the locus of points that follows the line of a black-body radiator (shown in Fig. 1). An incandescent lamp has a black-body temperature of approximately 2700 K. Most fluorescent lamps are designed to have a color temperature of between 3000 K and 5000 K, dependent on the application and preference of the user.

Another key requirement of illumination relates to the spectral properties of the white light source. Our perceived color of objects depends upon the spectrum of incident light upon them.

TABLE I
VALUES OF COLOR RENDERING INDEX
(R_a) REQUIRED FOR A NUMBER OF
ILLUMINATION APPLICATIONS.

Indoor retail	R_a 90+
Indoor office / home	R_a 80
Indoor work area	R_a 60
Outdoor pedestrian area	R_a 60+
Outdoor general illumination	R_a 40-

TABLE II
VALUES OF COLOR RENDERING INDEX (R_a) THAT CAN BE ACHIEVED
WITH THE COMBINATION OF TWO, THREE, AND FOUR
DIFFERENT WAVELENGTH LEDs.

500nm + 595nm	R_a 40
470nm + 540nm + 610nm	R_a 80+
465nm + 535nm + 590nm + 625nm	R_a 90+

A red object illuminated with light that is drastically deficient in red will appear black. The lighting industry uses a standard color rendering index (R_a) to determine the color rendition properties of a light source. It is based on the components of eight standard spectra in the white light source as compared to a black-body radiator with the same color temperature as the light source. Thus, an incandescent lamp has an R_a value of 100. Typical fluorescent lamps used in offices have an R_a of 80. The required R_a value depends upon the application. Typical examples are given in Table I.

The illumination of goods in a retail store is typically the most demanding application for color rendering index. The precise requirements depend upon the goods being displayed. As the goods on display are changed, different color points may be desired. With conventional light sources, this means that the lamp has to be changed. RGB-LEDs will allow the desired color point to be achieved simply by adjusting the ratio of RGB illumination. Typical indoor living space is illuminated with sources that have an R_a of 80. The color temperature can vary from 2700 K with incandescent lamps, to the 4000 K typically used in offices with fluorescent lighting. RGB-LEDs will allow one lamp to provide a range of color temperatures. General outdoor illumination such as street lighting puts the lowest demands on color rendering with R_a of 40 or less being common.

The R_a that can be achieved with LEDs depends on the white spectrum. The white spectrum is made up of the individual LED spectra, and thus, depends on the wavelengths selected, and the number of different wavelength LEDs used to make white light. Table II shows the R_a values that can be achieved with the mixing of two, three, and four different wavelength LEDs.

RGB-LEDs can achieve the required R_a values provided that the correct LED wavelengths are selected. Most applications can be addressed by the selection of three different wavelengths.

A major requirement of many illumination applications is that the light source has the required color point (i.e., (u, v) coordinate), and that it stays at its color point over time. It is viewed as unacceptable if all fluorescent lamps lighting in an office area are not the same color. This raises the question: what is the required specification? There is no single answer—it de-

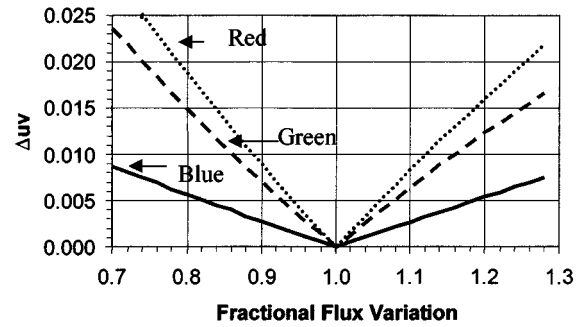

Fig. 2. The calculated shift in the (u, v) color coordinates as a result of a change in the flux of the red, green, or blue LEDs in an RGB-LED.

pends upon the application. To quantify the color error of a light source, we introduce the quantity Δuv where

$$\Delta uv = ((u - u_o)^2 + (v - v_o)^2)^{0.5}$$

(u, v) being the color coordinates of the light source, and (u_o, v_o) are the required color coordinates. This is simply the distance in (u, v) color space of the lamp from the desired color point (see Fig. 1). As a point of reference, fluorescent tubes are usually specified to be within $\Delta uv = 0.003$ of their designed color point. Some discharge lamps have larger deviations of over $\Delta uv = 0.01$, and are regarded as unacceptable by some customers. As we will show below, the demands on color reproducibility of the general illumination market provides a severe challenge for RGB-LEDs. Color point reproducibility is also a severe challenge for most approaches to phosphor-LEDs. No phosphor-LEDs on the market today meet the color point reproducibility requirements of the general illumination market.

III. THE COLOR STABILITY OF RGB-LEDs

Conventional light sources (fluorescent, incandescent, etc) can be manufactured very reproducibly such that the lumen output and color points are highly consistent (a few percent in flux and a Δuv of less than 0.003). As a result, the general illumination market has grown to expect this level of consistency. The manufacturing process for LEDs, on the other hand, does not provide this level of consistency. Nominally identical LEDs can vary in light output by over a factor of two, and the wavelength can vary by many nanometers. Lumen output and wavelength also change with temperature [6] and lumen output changes over time in a way that cannot be accurately predicted. These factors all influence the color point that is obtained by mixing the light from a combination of different wavelength LEDs. We now discuss the quantitative effect of these LED characteristics based on white light from RGB-LEDs.

The largest impact on color point of RGB-LEDs comes from changes in light output of the individual LEDs. This can be as a result of aging, or from the initial spread in the performance of the LEDs used in the lamp. Fig. 2 shows a calculation of the color error that occurs if any one of the red, green, or blue components changes in intensity. At a color temperature of 3000 K, a change of less than 10% in intensity of either green or red moves the color point by $\Delta uv = 0.005$, already outside the specification of a fluorescent lamp. This is a very small intensity change

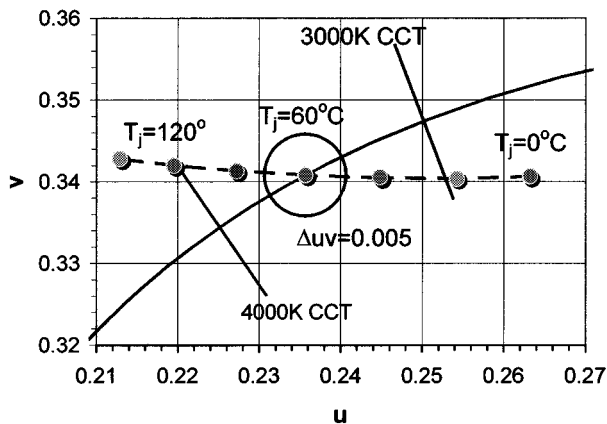

Fig. 3. The calculated shift in (u, v) coordinates of an RGB-LED as the temperature is changed in increments of $20\text{ }^{\circ}\text{C}$. The RGB-LED has a color temperature of 3500 K for a junction temperature of $60\text{ }^{\circ}\text{C}$.

compared with the variability in nominally identical LEDs. Relative changes over lifetime between the different LEDs can be far greater than 10%.

Change in temperature of the LED pn junction leads to changes in light output, wavelength and spectral width. These all influence the resulting color point of the RGB-LED. This is illustrated in Fig. 3, which shows the calculated change in color point on the (u, v) plane as the temperature changes in increments of $20\text{ }^{\circ}\text{C}$. The system is set to be on the black body locus at a junction temperature of $60\text{ }^{\circ}\text{C}$, with a color temperature of 3500 K . The calculation is based on typical temperature coefficients of the LEDs. A shift in temperature of only $10\text{ }^{\circ}\text{C}$ moves the color point by $\Delta uv = 0.005$. The largest contribution to this shift is the reduction of light output of the red LED as the temperature increases. As a result, the color point moves toward the blue-green. The red LEDs (or any AlInGaP-based LED), typically reduces its light output by 10–15% for every $10\text{ }^{\circ}\text{C}$ increase in temperature. If it were possible to reduce the temperature sensitivity of the red LEDs, the stability of white light from RGB-LEDs with temperature could be significantly improved.

In addition to the effects already discussed, the peak wavelength of an LED also shifts with current. Thus, as the intensity of RGB-LEDs is adjusted by changing the amplitude of the drive current to each of the LEDs, the color point of the combination will change. While this effect limits the accuracy of the color point, it is typically less critical than the effects shown in Figs. 2 and 3.

Changes in light output and peak wavelength with temperature, and changes in light output over time mean that factory calibrations will not be sufficient to produce a stable white light RGB-LED product. The large variability in the performance parameters of LEDs makes compensation schemes based on temperature measurement and time inadequate. The problem can be solved with appropriate feedback schemes used to control the color point. We now discuss how this can be done, and the performance those feedback schemes can achieve.

IV. FEEDBACK SCHEMES

There are several measurable quantities that can be used for compensation and feedback control schemes using thermal,

electrical, or optical sensors. The output of these sensors is fed to a feedback controller, which adjusts the current to the red, green, and blue LEDs to produce the desired white light output. In this section, we describe a number of different approaches to feedback control: temperature feed-forward compensation, flux feedback, combined temperature and flux control, and feedback of the color coordinates of the white light.

A. Temperature Feed Forward Compensation

The simplest measurement to implement is temperature. It is not practical to directly measure the junction temperature of the LED, and therefore, the temperature of the heatsink on which the LEDs are mounted is measured. Thus, only an indirect measurement of the junction temperature is made. As discussed above, the light flux and wavelength of an LED both vary with temperature. If the color point is correct at an initial set temperature, then the white color point can be maintained as the temperature changes provided that the temperature dependence of the flux and wavelength of each color LED is known. At each temperature the required fluxes of the red, green, and blue LEDs must be calculated based on the calculated wavelengths for that temperature. The currents required to produce that flux must also be calculated for each color LED. A problem with this method of compensation is that the temperature dependence of the flux and wavelength are not precisely known. These LED parameters have a significant distribution just as the efficiency and wavelength do (see Section III). This introduces significant errors in the resulting white color point. An additional problem with this simple compensation scheme is that it does not correct for changes in LED flux with time. Given the variability in the aging characteristics of LEDs, adding a simple correction based on hours of operation would not adequately address the issue.

B. Feedback Control of the LED Flux

Photodiodes can be used to measure the LED flux of each color component directly. The feedback controller simply has to maintain the preset flux from each color component to roughly maintain the white point. This can be done with a set of three photodiodes, each photodiode placed to detect only a single color component. It is also possible to use pulsing techniques such that only a single photodiode is needed to monitor each of the three color components. Feedback control of the fluxes of each of the color components will correct for the LED aging and the variation of LED flux with temperature. This provides improved white light control compared to that obtained with temperature feed forward alone, and does correct for the aging of the LEDs. The disadvantage of this approach is that it does not correct for the shift in wavelength with temperature. Calculation shows that temperature changes of $20\text{ }^{\circ}\text{C}$ can result in a color point shift Δuv of more than 0.005.

C. Combined Temperature and Flux Feedback

An improved feedback control system can be achieved by combining both temperature feed forward and flux feedback. This has all the advantages of the flux feedback discussed above, and uses the temperature feed forward to allow corrections to be made for the shift in wavelength with temperature. This scheme

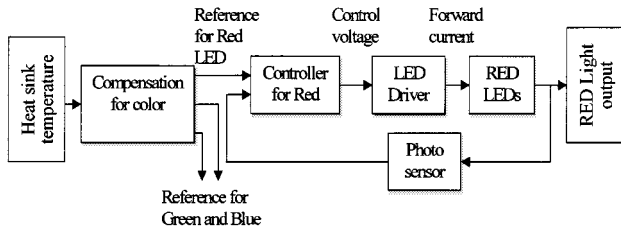

Fig. 4. Block diagram of a control system with temperature feed forward and LED light output feedback.

still relies on knowing the temperature dependence of wavelength on temperature, and thus suffers from the spread in LED characteristics. Fig. 4 shows a block diagram of such a control system. The compensation system supplies reference red, green, and blue light outputs as a function of temperature to three independent single-input-single-output (SISO) feedback controllers, which regulate the RGB-LED light outputs to the reference values.

D. Feedback of the Color Coordinates

Direct control of the white light from RGB-LEDs can be achieved by measuring the color coordinates of the white light. The measurement requires sensors with spectral responses matching the CIE 1931 color matching functions. The feedback signal then gives the (X, Y, Z) color coordinates. The sensors would consist of three photodiodes each covered with an appropriate optical filter. A properly designed controller then directly regulates the white light to the target color point. A high degree of color accuracy is possible with this scheme. However, there can be errors in sensing the tristimulus values due to inaccuracies in the color filters used. This tristimulus feedback control overcomes the variability in LED performance since it directly controls the white light, and not the components that go to make up the white light. Such feedback schemes, therefore, have the potential to be more accurate than the control methods described above.

Either pulsewidth modulation (PWM) or amplitude modulation (AM) can be used to supply the LED forward current with the feedback schemes presented above. However, PWM and AM driving conditions affect the spectral response of the LEDs differently. A change in the amplitude of the drive current of an LED causes a shift in its wavelength, as described above. Control methods that do not measure the color coordinates directly must take account of this if AM drive schemes are used. In the case of PWM driving of the LEDs, the current does not affect the wavelength of the LED as the dc forward current is always at the same value.

V. AN EXPERIMENTAL CONTROL SYSTEM

We have carried out experimental verification of the operation of a feedback control system for RGB-LEDs with temperature feed forward and flux feedback. We now describe the experimental setup and present the results obtained.

Fig. 5 shows a schematic of an RGB-LED white light source with this type of feedback control. The white light source is constructed from four red LEDs, eight green LEDs, and four blue LEDs. The LEDs are mounted on a heat sink using thermally

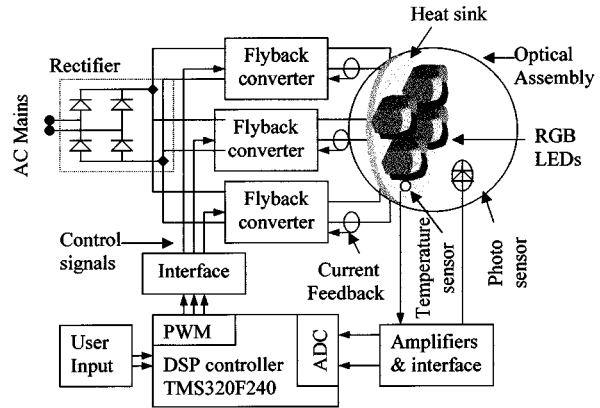

Fig. 5. Schematic of an RGB-LED lamp with feedback control system.

conducting epoxy. A single temperature sensor (LM35 from National Semiconductors) is used to measure the temperature of the heat sink. The heatsink has a heater on it so that the temperature can be varied. A single Si photodiode (VTB113 from EG&G) is used to measure the light output from the red, green, and blue LEDs. The LEDs and the photodiode are mounted inside an integrating sphere to provide ideal mixing of the light from the different wavelength LEDs, to ensure that the photodiode sees all the LEDs equally, and to shield the experiment from ambient light. The integrating sphere is connected to a spectral lamp measurement system (spectrometer) to measure the chromaticity coordinates of the mixed white light. This is used to measure the performance of the feedback system. In an actual illumination system, the integrating sphere would be replaced by color mixing optics suited to the application.

Three independent flyback converters operating at a constant switching frequency of 100-kHz drive the RGB-LED light source. We used a PWM driving scheme operating at a frequency of 120 Hz for these experiments. Each flyback converter contains a current loop to maintain a constant peak current for the PWM pulses. In order to minimize the rise time and the fall time for the PWM current pulses, a small value of output filter capacitance is used. In addition, an inductor in series with the LEDs is used to reduce the current ripple. The color control system (shown in Fig. 4) is implemented in a DSP TMS320F240, which supplies the PWM turn-on and turn-off signals for the power supply.

The photodiode measures the flux of each of the three LED wavelengths according to the scheme shown in Fig. 6. In this example, it is assumed that the duty ratio for green is largest, and for blue is smallest. The rise and fall times for the current pulses are assumed to be negligible. In Fig. 6, the start of the PWM current pulse for red is aligned at the start of the overall PWM period, the pulse for green is centered in the period, and the end of the pulse for blue is aligned at the end of the period. Although many other configurations are possible, the pulse positioning shown in Fig. 6 provides a complete measurement in a single PWM period. The light measurements are taken in a predefined sequence of four points during the PWM cycle. The individual flux components of the red, green, and blue LEDs are obtained by differential measurements as follows: Each photodiode measurement provides the flux from one or more colors plus any ambient light. Subtracting the fluxes at two of the measurement

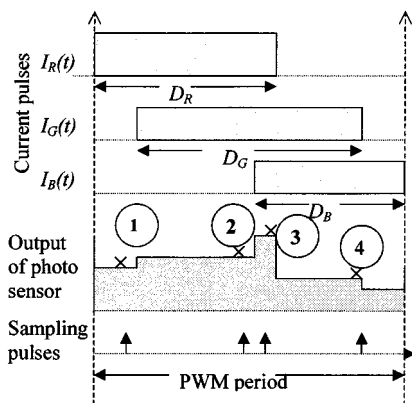

Fig. 6. Light measurement using a single photosensor with the elimination of ambient light.

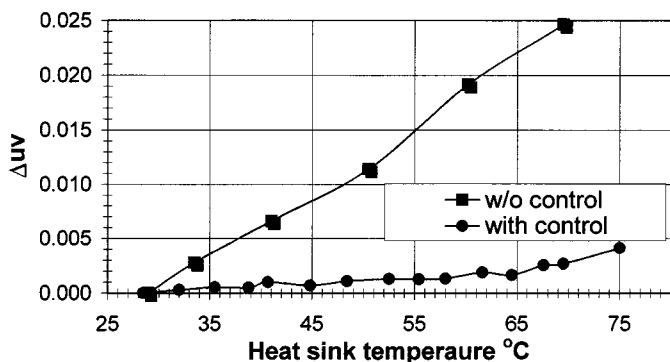

Fig. 7. The measured color error as a function of heat sink temperature of an RGB-LED lamp both open loop, and with a control system using temperature feed forward and flux feedback.

points gives the LED fluxes with the ambient light component eliminated. The red, green, and blue fluxes are given by the difference between measurements three and four, two and one, and three and two, respectively.

The experimental setup as described was used to examine the performance of this type of feedback scheme. The system was initially calibrated at a fixed temperature by adjusting the relative drive currents of the red, green, and blue LEDs until the spectrometer showed that the desired color point had been achieved. The white point was then monitored with the spectrometer as the temperature of the heatsink was slowly increased. The experimentally measured color shift for an open loop system is shown in Fig. 7. The result shows a color shift Δuv of about 0.005 for a temperature change of 10 °C, comparable to the predicted shift shown in Fig. 3. Fig. 7 also shows the performance of the feedback control system with variation in temperature. The color point only changes by $\Delta uv = 0.004$ with a temperature change of 50 °C. The change in lumen output over the same temperature change was found to be less than 3%. These results show that this type of control system can be used to produce a stable white light source from RGB-LEDs.

VI. STATISTICAL ANALYSIS OF PRODUCT YIELD

The experimental results discussed above have demonstrated the ability of the feedback system to maintain a precalibrated white point. However, what happens if no calibration is performed, and the set of LEDs is picked out of the production dis-

tribution at random? A statistical model has been developed to study this issue.

An LED light source is constructed from six red, six green, and six blue LEDs. Each LED is characterized by a number of parameters including flux (lumens per amp), wavelength, spectral width, forward voltage (V_f), and temperature coefficients of flux and wavelength. The values of these parameters are assigned at random based on a Gaussian distribution that approximates typical distributions of each parameter achieved in production. The LED spectrum is modeled as a second-order Lorentzian. All these parameters are based on a junction temperature of 25 °C. The LED junction temperature at a given heatsink temperature is calculated from the power dissipation (the product of current and V_f), and the thermal conductivity from the chip to the heatsink. We assume ideal optical mixing such that the white light output is a combination of all 18 LEDs in the lamp. The required drive currents for the red, green and blue LEDs to generate white light can be calculated based on the nominal performance of the LEDs (i.e., the mean of the Gaussian distributions for each of the LED performance parameters).

Once the LED performance parameters are selected, the actual color point of the lamp can be calculated. This can be compared with the designed color point, and a color error (Δuv) calculated. The color error will be dependent on the actual performance parameters selected, and those over a large number of LED lamps will have a statistical distribution. We typically calculate the color error for 5000–10000 lamps to determine this distribution. From the distribution of color errors, the product yield for a maximum acceptable color error can be calculated. The model can also calculate the effect of compensation and feedback schemes on the white light performance. The steady state function of a given control system is also included in the simulation together with a model for the sensors and LED drivers. The effect of AM or PWM driving scheme can also be modeled.

A number of different control schemes have been modeled, providing the product yield as a function of color accuracy. The modeling results for three different control schemes are shown in Fig. 8. The simplest control scheme involves only temperature feed-forward compensation (see Section IV). The simulation results show that less than 20% of products will have a color error of less than 0.005. It is clear that this control scheme will not achieve the performance required for illumination applications. If the control scheme is extended to include flux feedback of the red, green, and blue components (see Section V), a much improved product yield is achieved. As shown in Fig. 8, over 80% of products will have a color error of less than .005, and 100% yield is achieved with a color error of 0.01. We also show the result of a more complex feedback scheme that uses a wavelength feed-forward compensation scheme in addition to flux feedback. Color filters together with photodiodes are used to sense the wavelength shifts from the nominal value. This approach can further improve product yield, giving 98% yield for a color error of only 0.005.

The results of our simulations show that it is possible to design feedback control systems for RGB-LEDs that are capable of producing the required color accuracy for illumination ap-

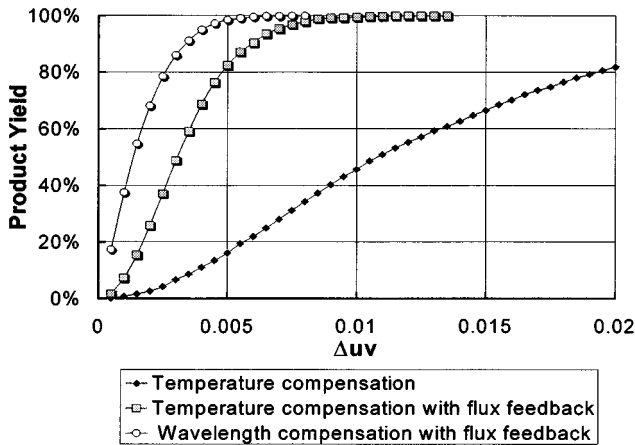

Fig. 8. The calculated product yield as a function of maximum color error for three different feedback control systems.

plications despite the large variability in LED characteristics. In the results presented in Fig. 8 we have assumed that each of the control measurements (temperature, flux, etc) are without errors. In practice, there will be some errors in the feedback signals themselves arising from the characteristics and variability of the feedback sensors. These inaccuracies can also be modeled, and their effect on product yield determined. We find that it is important to keep such measurement errors to only a few percent. The performance of feedback control schemes can be improved with the addition of some limited factory calibrations. This can take the form of a measurement on the finished lamp, or by preselecting a smaller range of performance characteristics for the LEDs used to construct the lamp.

VII. SUMMARY

We have shown both experimentally and theoretically that practical white light sources can be produced from a combination of red, green, and blue LEDs. The requirements of the illumination market for color accuracy are very stringent. Typically, the white point must be accurate to better than $\Delta uv = 0.005$. Due to the variability in LED performance parameters, and the dependence of flux and wavelength on temperature, it is not possible to achieve the required color accuracy without an electronic control system. A feedback control system using temperature feed-forward compensation and flux feedback achieves the required level of color control and a relatively high product yield of over 80% for typical variation in LED characteristics. Further improvements can be made to the feedback scheme to give very high product yields of over 95%. Such control systems will enable lighting systems to be developed that bring new illumination features to the market. RGB-LED light sources will provide

variable color sources, such that the user can select the desired color point as well as the desired intensity from a single lamp.

The success of this type of light source in the general illumination market will depend on efficacy and cost. The rapid improvement in LED efficiencies indicate that within the next few years, LED white light sources will be available that can meet the efficacy of current compact fluorescent lamps. The challenge ahead is to reduce the cost of the LED lamp, including the LED chips and feedback control system.

REFERENCES

- [1] M. G. Craford, "LED's challenge the incandescents," *IEEE Circuits and Devices Mag.*, vol. 8, pp. 24–29, Sept. 1992.
- [2] —, "Visible light emitting diode technology: High performance, more colors, and moving into incandescent lamp applications," in *Quantum Electronics and Laser Science Conf.*, 1996, pp. 28–28.
- [3] R. Haitz, "Another semiconductor revolution: This time it's lighting," in *Proc. Ninth International Symposium on the Science & Technology of Light Sources*, 2001, pp. 319–328.
- [4] C. Holen and G. Harbers, "LCD backlighting with high luminescent colored light emitting diodes," in *Proc. Ninth International Symposium on the Science & Technology of Light Sources*, 2001, pp. 373–374.
- [5] G. Wyszecki and W. S. Stiles, *Color Science*. New York: Wiley, 1982.
- [6] A. Bergh, G. Craford, A. Duggal, and R. Haitz, "The promise and challenge of solid-state lighting," *Physics Today*, pp. 42–47, Dec. 2001.

Subramanian Muthu (A'95) received a B.E. degree in electrical engineering from Bharathiyar University, India, the M.Tech. degree from the Indian Institute of Technology, and the Ph.D. degree from the University of Victoria, B.C., Canada, in 1985, 1992, and 1998, respectively.

From 1992 to 1994, he was with Indian Telephone Industries. Since 1998, he is a senior member of the research staff at Philips Research, Briarcliff Manor, NY. His main research interests include digital control of power converters and systems, inverters, active filters, white light control of light-emitting diodes (LEDs), LED-based light generation, photovoltaic, and fuel cell power systems.

Frank J. P. Schuurmans received the M.Sc. degree in physics from the University of Utrecht, Utrecht, The Netherlands, and the Ph.D. degree in physics from the University of Amsterdam, Amsterdam, The Netherlands.

In 2000, he joined Philips Research, Briarcliff Manor, NY, where he worked on LED illumination. In 2001, he joined Philips Research in Eindhoven, The Netherlands, as the project leader of the Extreme Ultra Violet Lithography Program of Philips Research.

Michael D. Pashley received the B.Sc. degree in physics from the University of Bristol, Bristol, U.K., and the Ph.D. degree in physics from the University of Cambridge, Cambridge, U.K.

From 1982 to 1985, he was a research fellow at the University of Cambridge. In 1985, he joined Philips Research, Briarcliff Manor, NY. While at Philips, he has worked in the areas of surface physics, semiconductor lasers, and LED illumination. He is now a research department head.